



TD3 Thermodynamic Steamtrap

Description:

Thermodynamic steamtrap TD3 with built strainer and full stainless steel construction is best suited for header and mainline drains

Sizes and Pipe connections:

15NB and 20NB
screwed NPT and socket weldable ends

Notes:

1. Available with Class 150, 300 & 600 weld on flanges on request
2. Available with IBRC certificate

Pressure/temperature limits

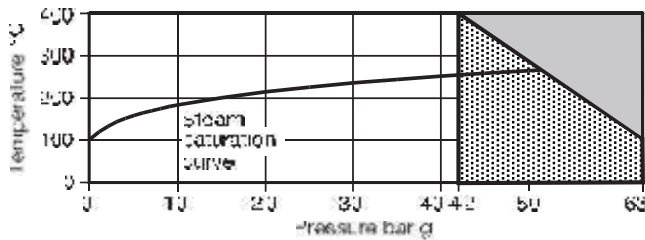

The product **must not** be used in this region.
 For optimum product performance the PMO should not exceed 42 bar g.

Body design conditions	PN63
PMAMaximum allowable pressure	63 bar g @ 100°C
TMA Maximum allowable temperature	400°C @ 42 bar g
Minimum allowable temperature	0°C
PMOMaximum operating pressure	42 bar g recommended
TMOMaximum operating temperature	400°C @ 42 bar g
Minimum operating temperature	0°C

Note: For lower operating temperatures consult Spirax Marshall

Maximum back pressure should not exceed 80% of the inlet pressure under any conditions of operation otherwise the trap may not shut-off.

Minimum operating differential pressure for satisfactory operation 0.25 bar g

Designed for a maximum cold hydraulic test pressure of 95 bar g

Optional extras :

ISOTUB - An insulating cover (part no. 6). To prevent the trap being unduly influenced by excessive heat loss such as when subjected to low outside temperatures, wind rain etc.

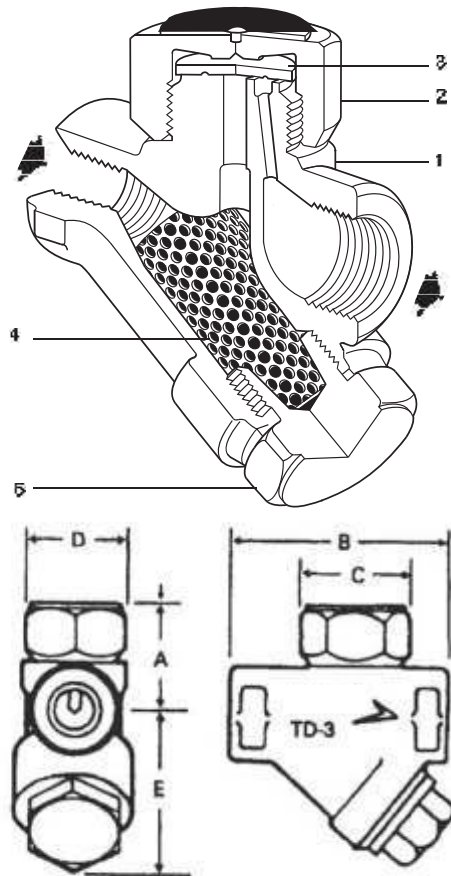

Dimensions : (approx.) mm

Size	A	B	C	D	E
15 NB } 20 NB }	42	78	50	44	57

Materials :

Sr. No.	Part	Material	Standard
1.	Body	St. Steel	ASTM A 743 GR-CA 40
2.	Cap	St. Steel	ASTM A 743 GR-CA 40
3.	Disc	St. Steel	ASTM A 743 GR-CA 40
4.	Strainer Screen	St. Steel type 304	ASTM A 240
5.	Strainer Cap	St. Steel	ASTM A 743 GR-CA 40

Installation:

Preferably on horizontal pipe with cover on top can be fitted in other positions if unavoidable.

Salient Features:

1. Complete stainless steel construction ensures better mechanical and corrosion resistant properties.
2. The disc and seat, hardened by induction hardening process to about 45Rc to enable with stand continuous water hammering condition.
3. Seat integral part of the body, eliminates leakage-prone joints and gaskets.
4. Condensate entry below the disc concentric to disc/seat, ensures clean and parallel lift of disc with reference to seat, eliminating any localized wear and tear.
5. An inbuilt strainer screen of adequately large area ensures long and trouble free operation.

removed in this way should not exceed 0.25 mm or 0.010". Alternatively, customers may prefer to take advantage of our reconditioned trap scheme which allows this work to be done to original production standards.

When re-assembling, the disc is normally placed in position with the grooved side in contact with body seating face. Screw on cap; no gasket is required but a suitable high temperature anti-sieze grease should be applied to the threads.

To clean or Replace Strainer:

Unscrew strainer cap using spanner, withdraw screen and clean or if damaged replace with new one.

To re-assemble, insert screen in cap, then screw cap in to place. No gasket is required but a fine smear of Molybdenum Disulphide grease should be applied to the threads.

Capacities

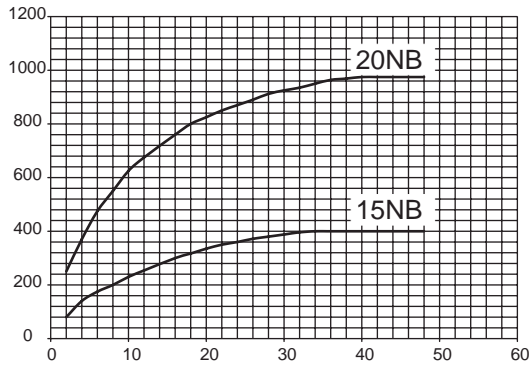

Available Spares:

The spare parts available are shown in heavy outline. Parts drawn in broken line are not supplied as spares.

AVAILABLE SPARES	
Strainer Screen & Disc (Pkt. of 3)	A+B
Isotub	C

How to Order:

Always order spares by using the description given in the column headed Available Spare and stating the size and type of trap.

Example : 1-Strainer Screen for 15NB Spirax Marshall TD3 Thermodynamic Steam Trap.

How to Service:

Remove isotub if fitted and unscrew cap using spanner. Do not use pipe wrench which may cause distortion of the cap. If the disc and body seating faces are only slightly worn they can be refaced by lapping individually on flat surfaces such as a surface plate. A figure of eight motion and a diluted 1:6 lapping compound such as 6 micron Al. Oxide gives the best results.

If the wear is too great to be rectified by simple lapping, these seating faces on the body must be ground flat and then lapped and the disc replaced by a new one. The total amount of metal

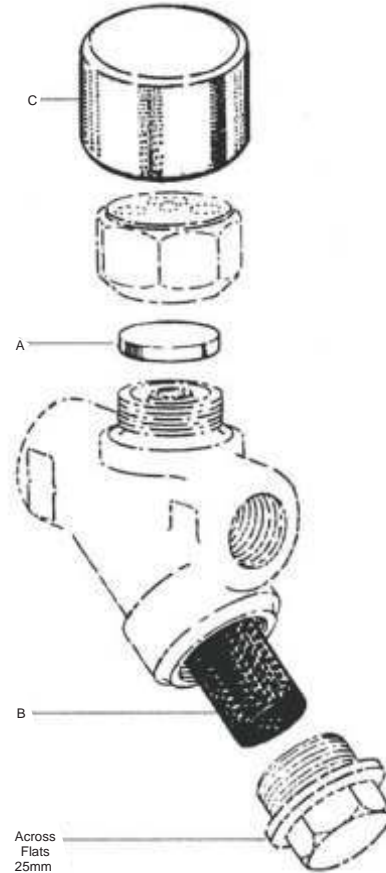

Recommended tightening torques

Item	or mm	Nm
2	42	M35 180-200
5	32	M28 170-190

STIS 39/R1

Qty./2009/3759

Subject to change without notice



M.M.K. Engineering Co. Pvt. Ltd.

Off. : Shop No 13, Shiv Sagar Sco., Near Eden High School, Safed Pool Pipeline, Krula-Andheri Road, Sakinaka, Mumbai-400 072. Maharashtra, India

Cell : +91- 97022 47169, 98707 57456 Telefax : + 91- 22- 2852 0185

Email : mmkenggc@gmail.com Website : www.mmkevalves.com